

Understanding ΔE CMC Colour Tolerance

For information applicable to KYDEX® FST please refer to 300 series technical briefs.

TB - 130-C

CMC Colour Tolerance

CMC is not a colour space but a colour tolerance represented by a single numerical value, ΔE . CMC is based on CIELCH where L is lightness, C is chroma, and H is hue.

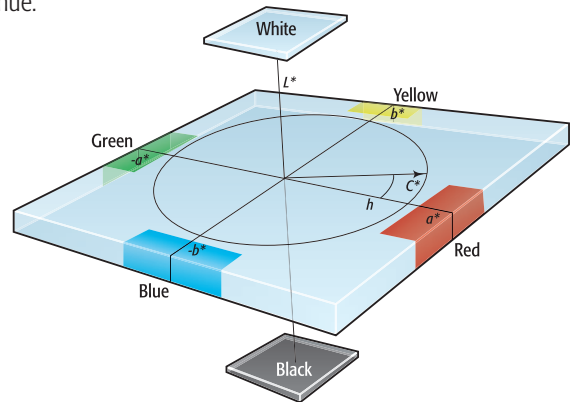
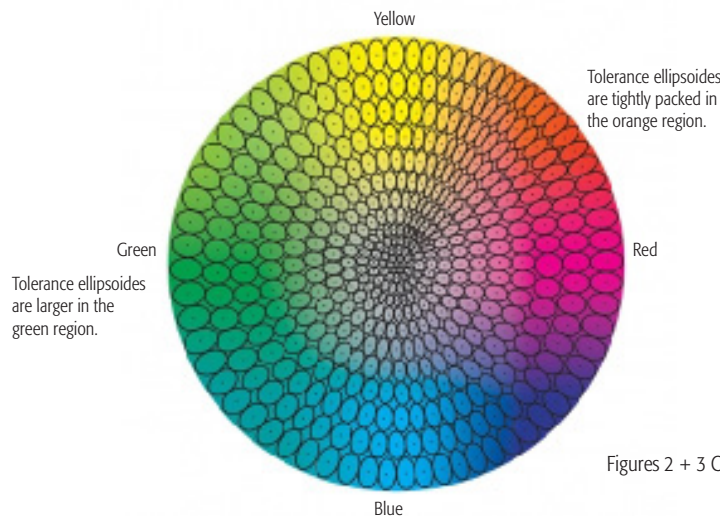
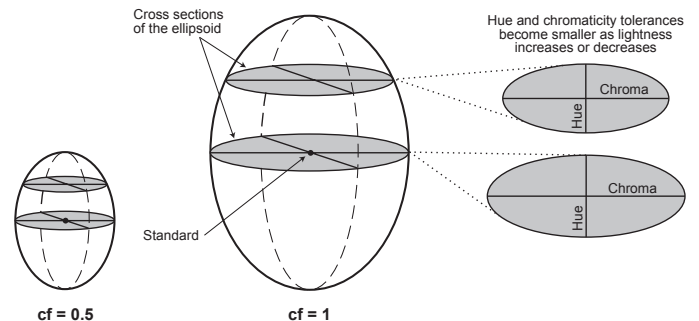

Figure 1 Coordinates of colour space (Eye-Color, 2002)

The CMC calculation defines an ellipsoid around the standard colour while the volume of the ellipsoid represents acceptable colour variation. The size and shape of the ellipsoid automatically varies depending on the location in colour space. Colours in the orange area of colour space are more sensitive to shifts in hue, which result in narrower ellipsoids, while colours in the green area of colour space have broader ellipsoids due to their low sensitivity to hue. Additionally, lightness will decrease hue and chroma tolerances as it increases or decreases from standard.



Figures 2 + 3 CMC tolerance of colour space (X-Rite, 2000)



SEKISUI SPI

ISO 9001:2008 and 14001:2004 Certified

Customer Service

6685 Low St, Bloomsburg, PA 17815 USA
Phone: 800.325.3133, +1.570.389.5810
Outside the US: +1.570.389.5814
Fax: 800.452.0155, +1.570.387.7786
Email: info@sekisui-spi.com

Technical Service

Phone: 800.682.8758
Fax: +1.570.387.8722
Outside the US: +1.570.387.6997
techservice@sekisui-spi.com

sekisui-spi.com

Understanding ΔE CMC Colour Tolerance

For information applicable to KYDEX® FST please refer to 300 series technical briefs.

TB - 130-C

CMC vs CIELAB Colour Tolerance

CIELAB colour tolerance is defined by the change in colour space on the L, a, and b axes where L is lightness, a is red/green, and b is yellow/blue. Limits placed on the ΔL , Δa , and Δb create a rectangular tolerance box around the colour standard. This evenly segments colour space into grids and assumes change in appearance is uniform throughout colour space.

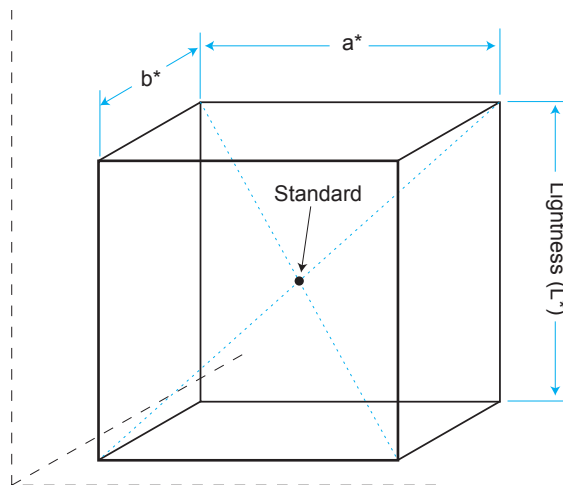
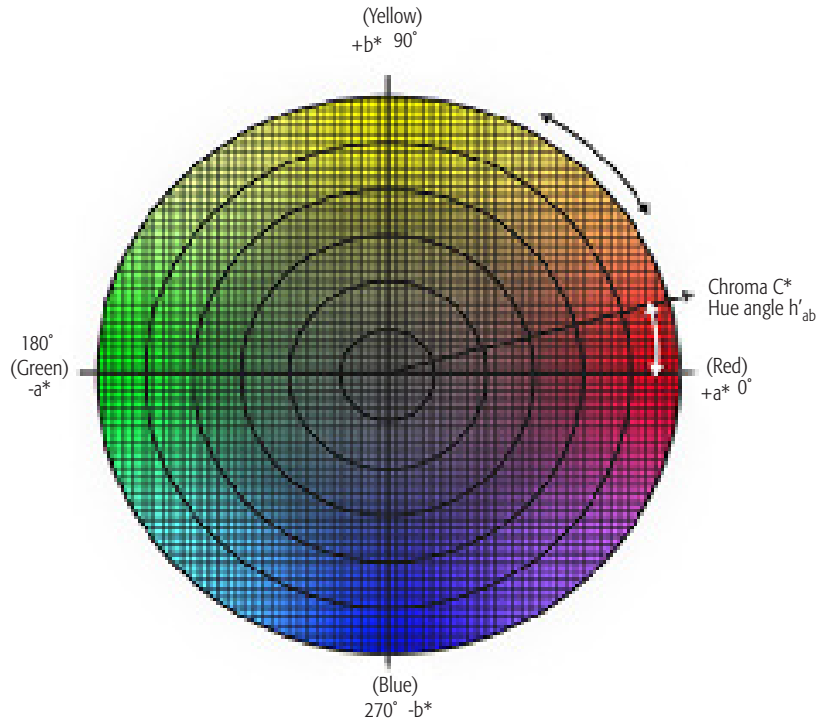

Figures 4 + 5 CIELAB tolerance of colour space (X-Rite, 2002)

SEKISUI SPI

ISO 9001:2008 and 14001:2004 Certified

Customer Service

6685 Low St, Bloomsburg, PA 17815 USA
 Phone: 800.325.3133, +1.570.389.5810
 Outside the US: +1.570.389.5814
 Fax: 800.452.0155, +1.570.387.7786
 Email: info@sekisui-spi.com

Technical Service

Phone: 800.682.8758
 Fax: +1.570.387.8722
 Outside the US: +1.570.387.6997
 techservice@sekisui-spi.com

sekisui-spi.com

Understanding ΔE CMC Colour Tolerance

For information applicable to KYDEX® FST please refer to 300 series technical briefs.

TB - 130-C

CMC vs CIELAB Colour Tolerance

The Human Observer and Visual Perception

The human eye does not detect colour differences in hue, chroma, or lightness equally. Various conditions including viewing conditions, eye fatigue, colour blindness, and colour memory can all affect the eye's ability to distinguish colour differences. On average, the observer will recognize differences in the hue first, chroma second, and lightness third. The resulting visual acceptability from the eye's ability to distinguish colour is best represented by an ellipsoid.

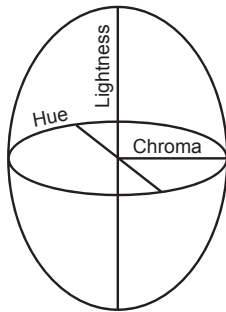

Figure 6 Visual colour acceptability ellipsoid (X-Rite, 2002)

While no colour tolerance system is perfect, the ellipsoid tolerance of CMC best represents the differences observed by our eyes. Research has shown that CMC tolerance has a 95% agreement with visual assessment while CIELAB has a 75% agreement. (X-Rite, 2002) Based on the higher degree of agreement, SEKISUI SPI utilizes CMC tolerance to inspect the colour of its thermoplastic sheet products.

References

Eye-Color. (2002). Color Spaces, CIE Lab_65percent.jpg retrieved online February 24, 2003, at http://www.i1color.com/knowledge/measuring_color.asp

X-Rite. (2000). A Guide to Understanding Color Communication.

SEKISUI SPI

ISO 9001:2008 and 14001:2004 Certified

Customer Service

6685 Low St, Bloomsburg, PA 17815 USA

Phone: 800.325.3133, +1.570.389.5810

Outside the US: +1.570.389.5814

Fax: 800.452.0155, +1.570.387.7786

Email: info@sekisui-spi.com

Technical Service

Phone: 800.682.8758

Fax: +1.570.387.8722

Outside the US: +1.570.387.6997

techservice@sekisui-spi.com

sekisui-spi.com